



La digital transformation di Versalis

E. Mantovani, A. Ferrando Versalis

erik.mantovani@versalis.eni.com

Versalis New Technological Platforms

I Big Data incontrano il Manifatturiero: Opportunità e Vantaggi – 15 Ottobre 2019

Overview

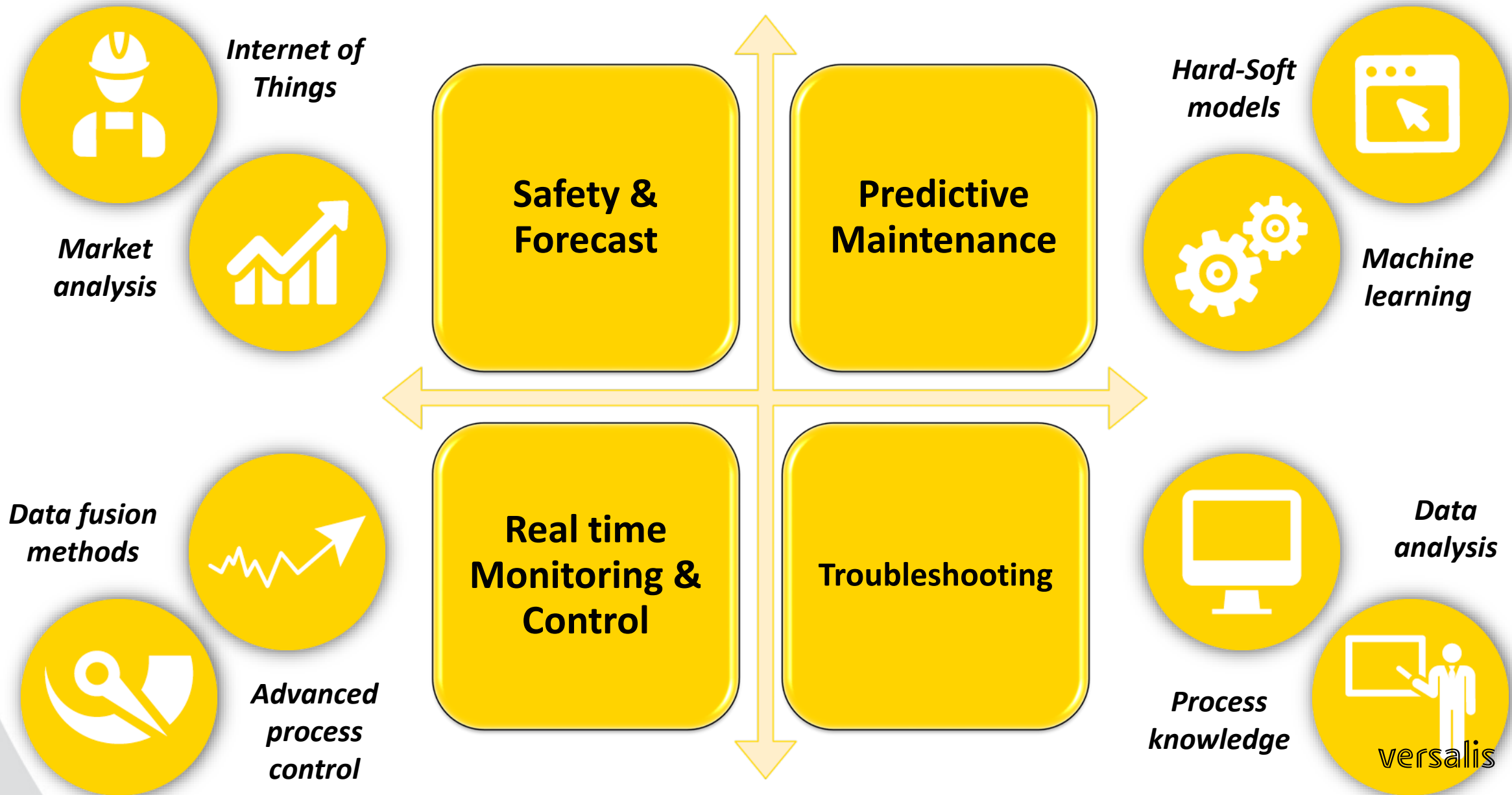

Petrochemical production and big data

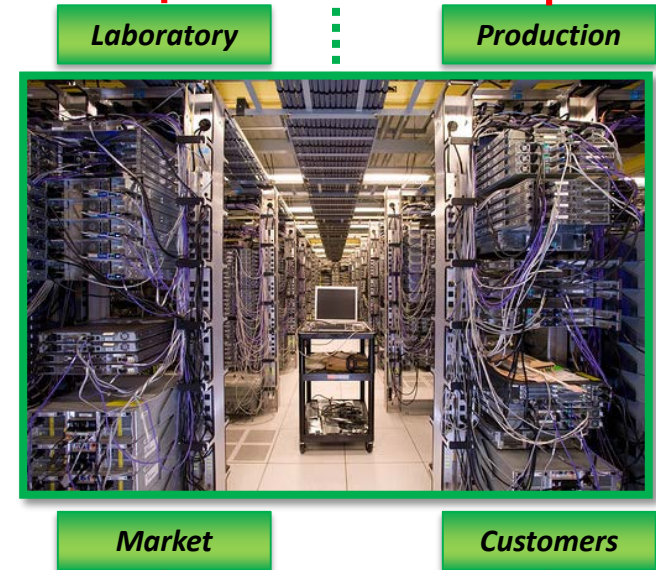
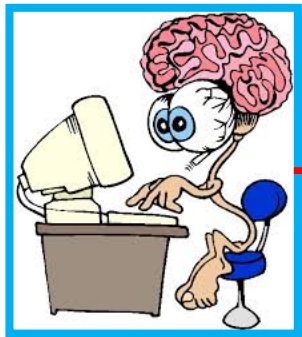

Petrochemical production and big data

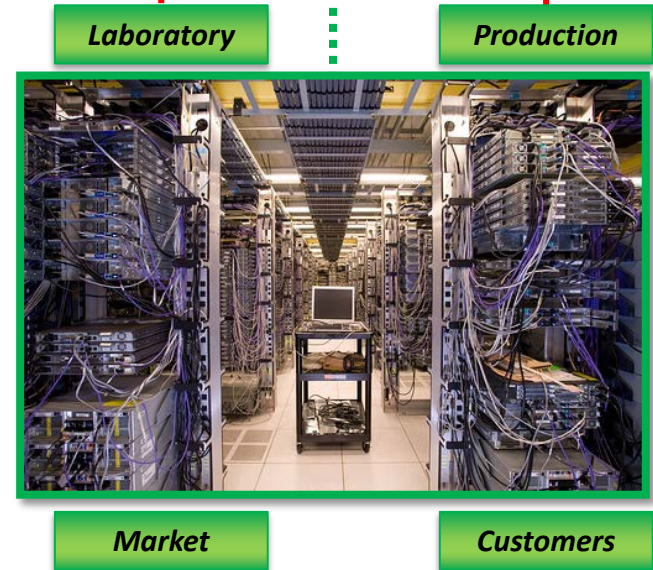
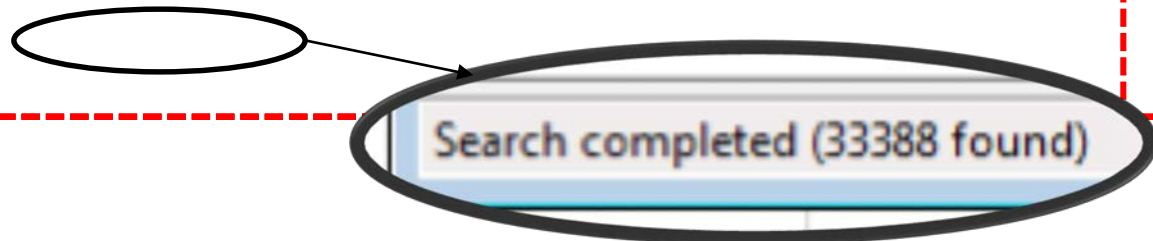

Petrochemical production and big data



$10^{*}4$ Sensors

New value every seconds



$10^{*}6$ values by day

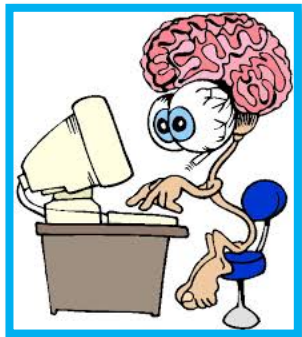
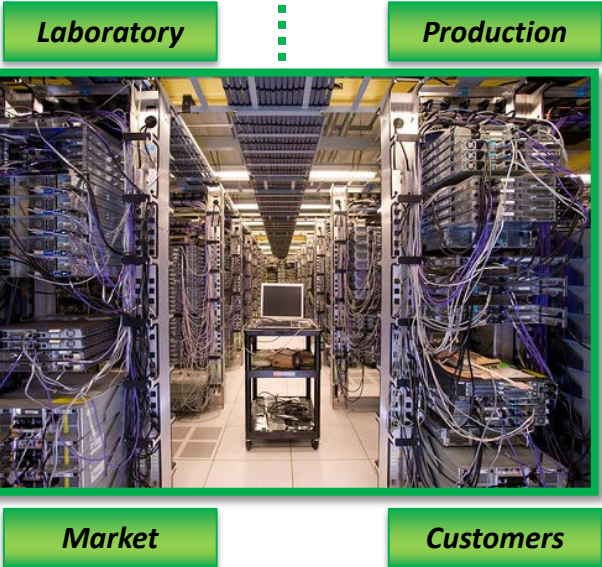

Petrochemical production and big data



Pictures



Classes

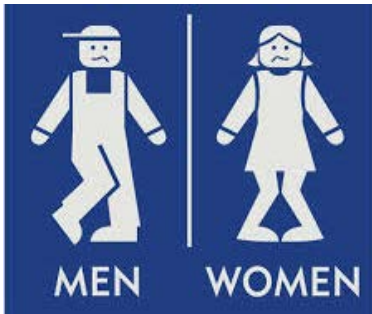

Process condition

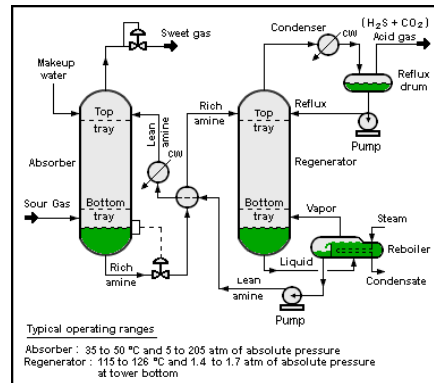

Typical operating ranges
Absorber : 35 to 50 °C and 5 to 205 atm of absolute pressure
Regenerator : 115 to 126 °C and 1.4 to 1.7 atm of absolute pressure
at tower bottom

Labs database

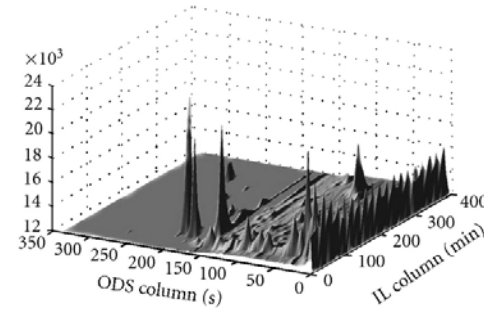

Laboratory

Production



Market

Customers

INFORMATION

Data analysis

- Pre-treatment
- Transformation
- Decomposition
- Regressions
- Supervised classifications
- Unsupervised classifications
- Etc.

INFORMATION

ACTIONS

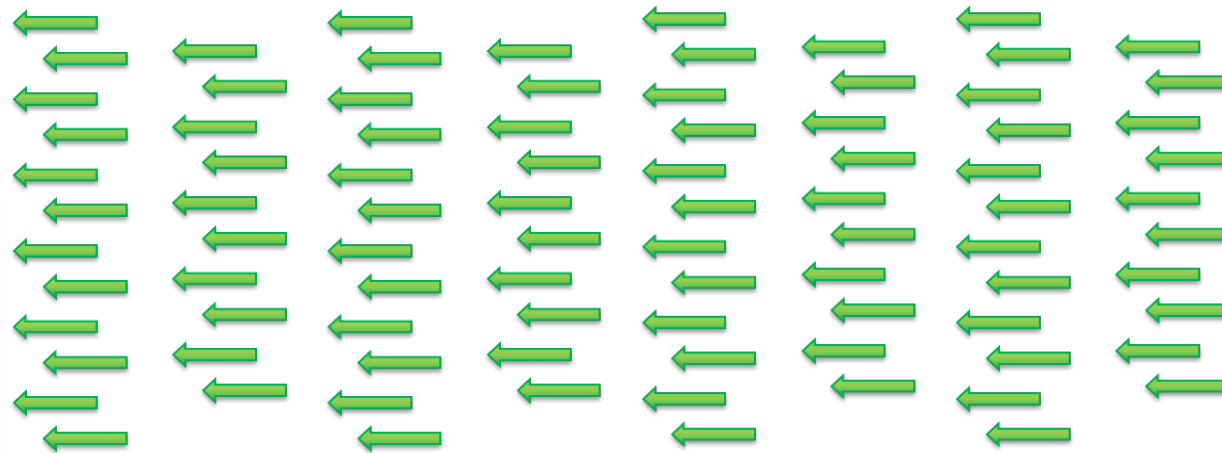
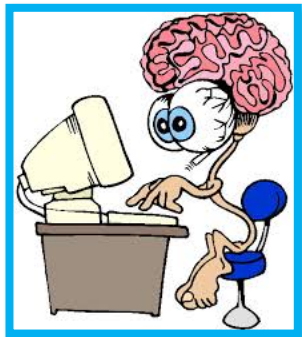

**Monitoring of polystyrene
production:
From lab to production**

**Lack of quality in polymers
production:
Troubleshooting analysis**

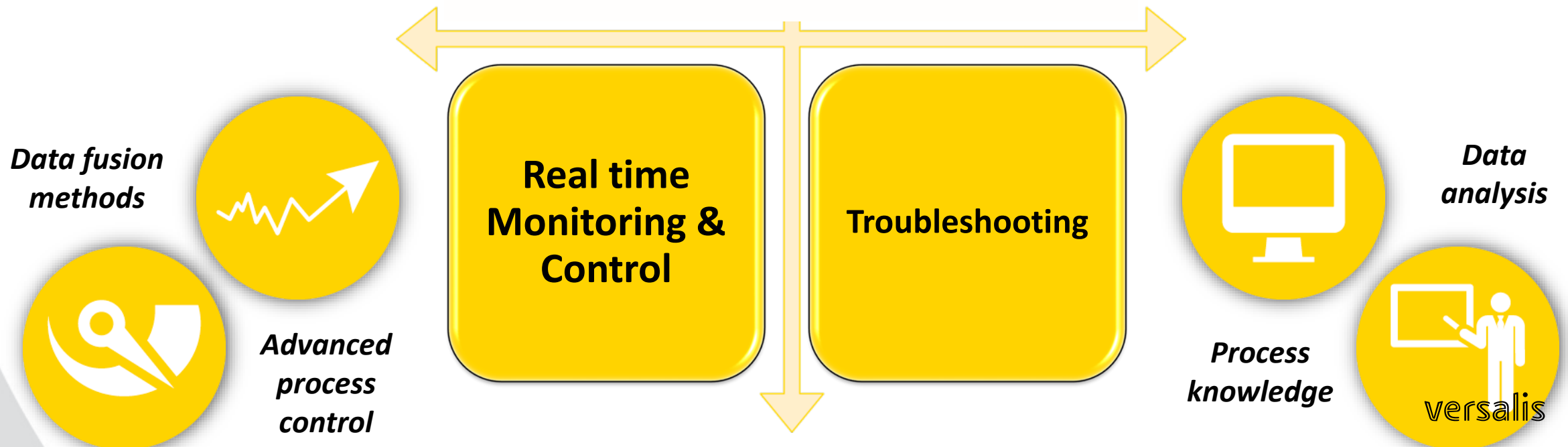

Monitoring of polystyrene production: From lab to production

Task – Monitoring of polystyrene production

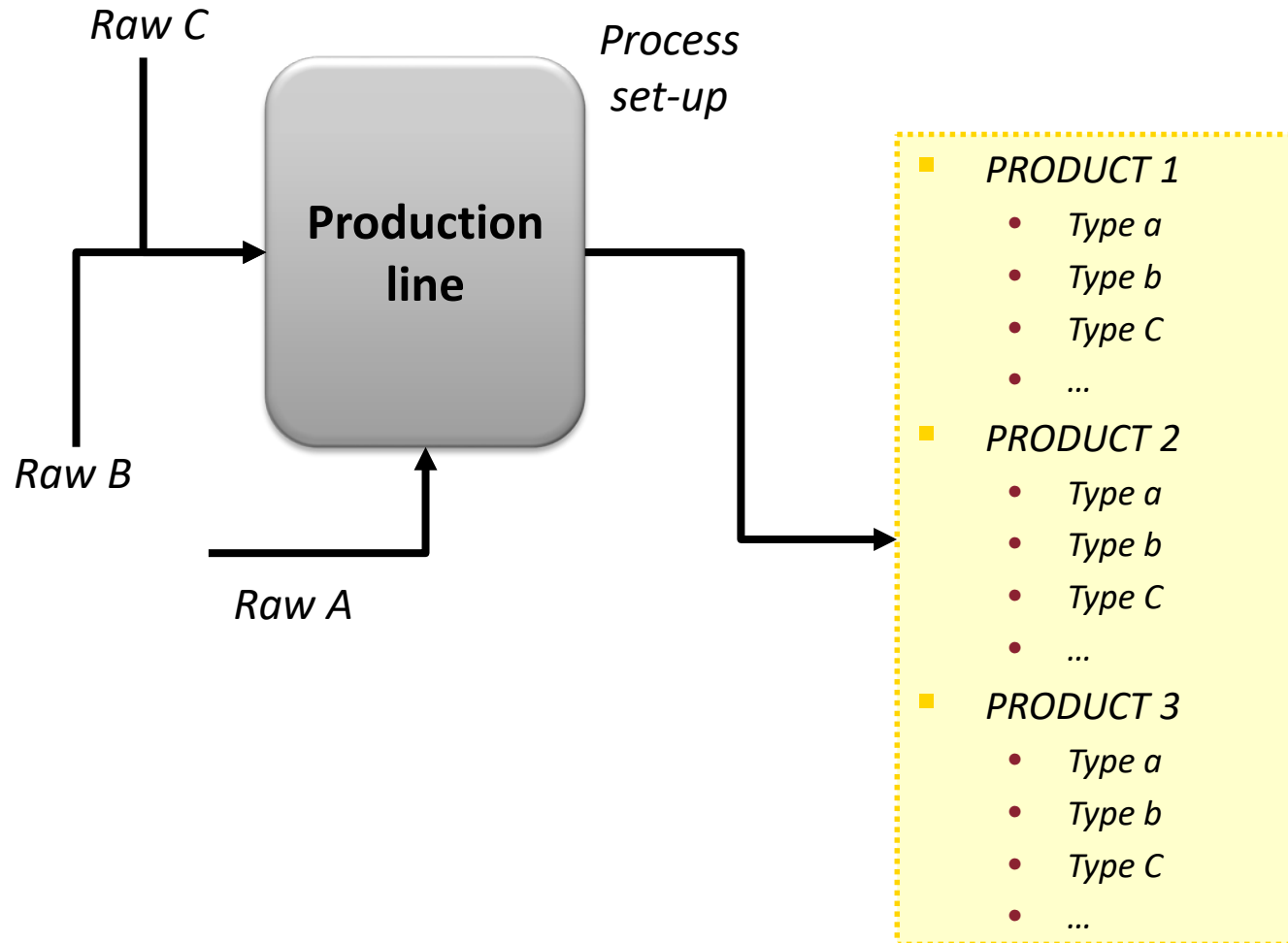

- Monitor quality on-line
- Define transition
- Reduce intermediate product
- Improve plant performances
- Etc.

Database – Monitoring of polystyrene production

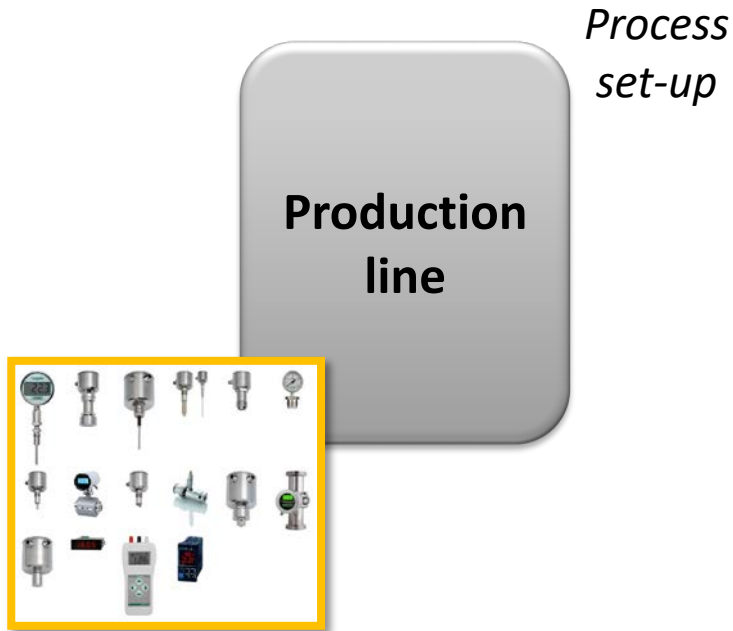

- *Production sensors*
(Thermocouples, flowmeters, level gauges, etc.)
- *Production sampling*
(Quality control made by laboratory)
- *New sensors installed production line*
(Each sensors returns many frequencies)

(N) Samples
x
(S) Sensors

(N) Samples
x
(F) Frequencies

(N) Samples
x
(A) Analysis

Analysis – Monitoring of polystyrene production



Process
set-up

Production
line

Data analysis

- Pre-treatment
- Decomposition
- Transformation
- Regressions

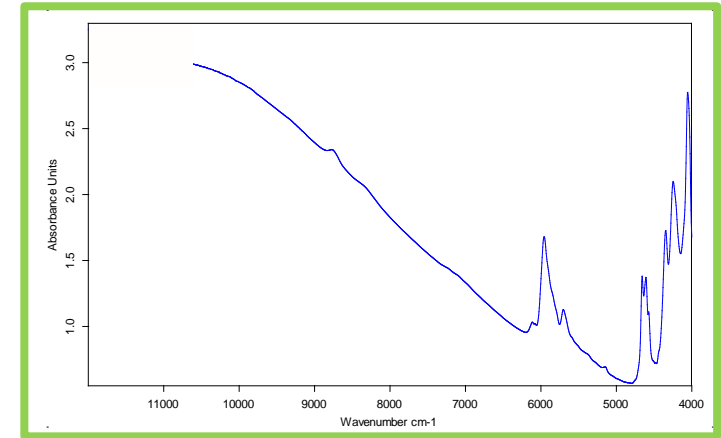

Each sensors

(N) Samples
X
(S) Sensors

(N) Samples
X
(F) Frequencies

(N) Samples
X
(A) Analysis

Physical
behaviour

Chemical
composition

versalis

Analysis – Monitoring of polystyrene production

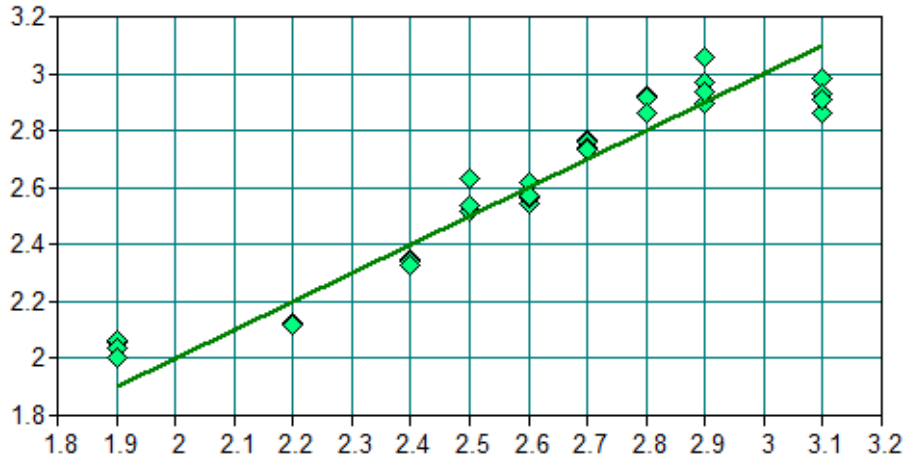

Rank: 3 $R^2 = 91.52$ RMSECV = 0.102 Bias: -0.00754 RPD: 3.44

Chemical composition

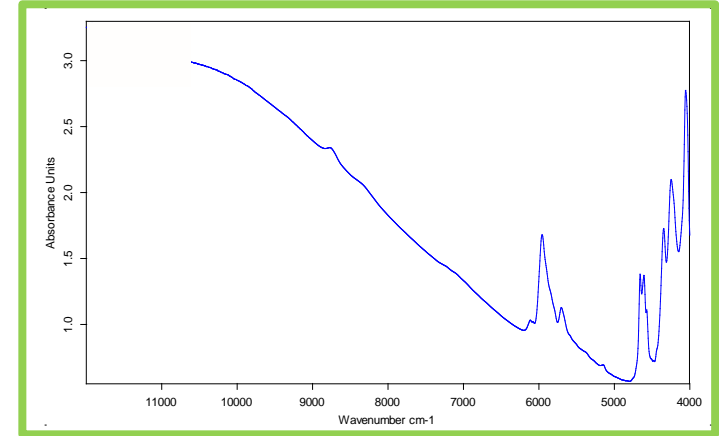
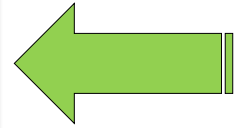

(N) Samples
x
(S) Sensors

(N) Samples
x
(F) Frequencies

(N) Samples
x
(A) Analysis

PLS
Partial Least Square
Prediction in Latent Structure

Analysis – Monitoring of polystyrene production

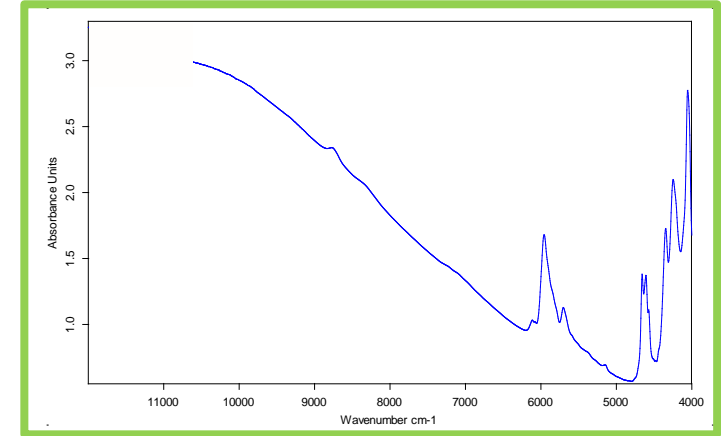
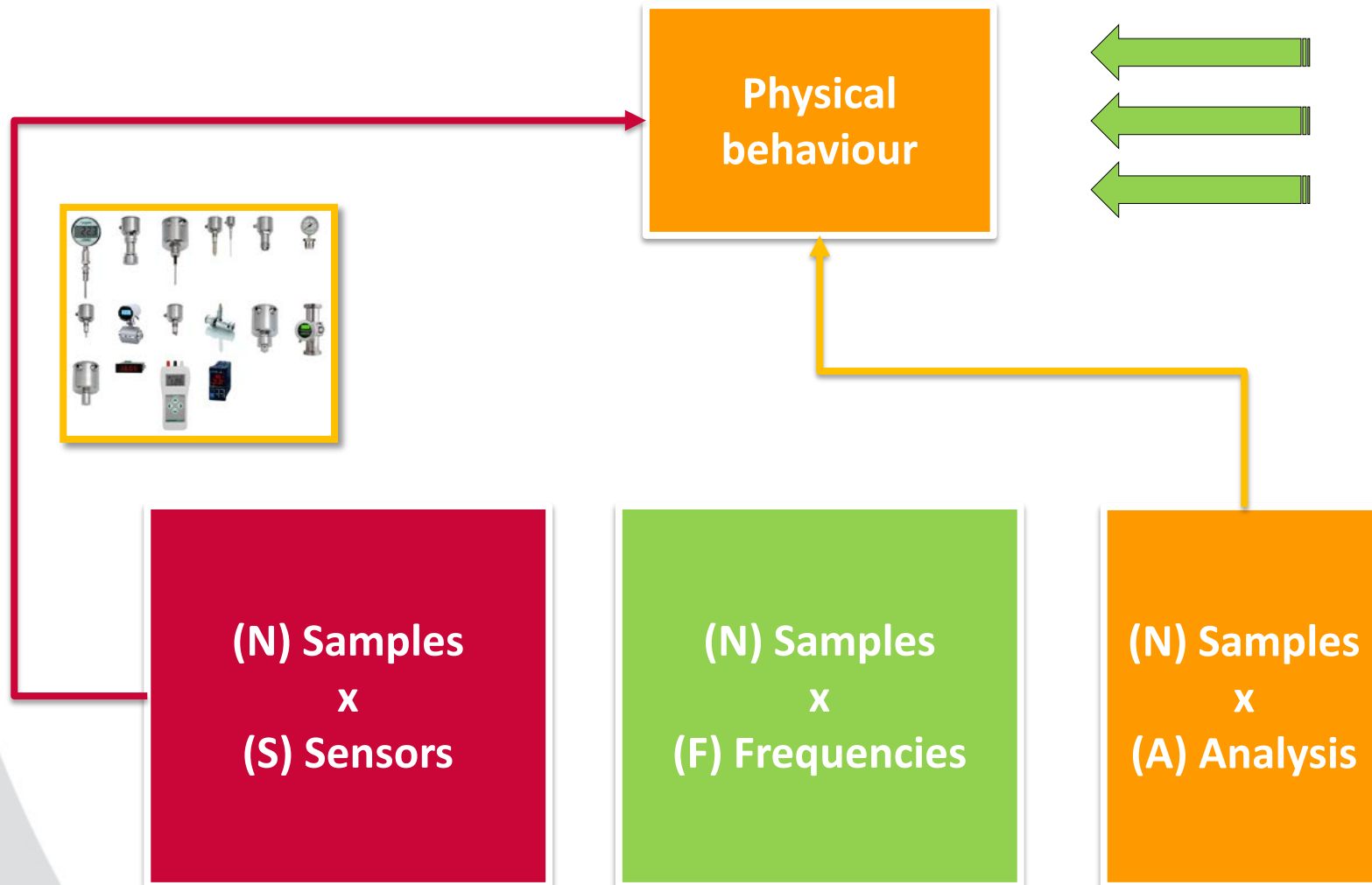

DATA FUSION

Extract information from each datasets

Transform and merge

Define the relationship with physical feature

Information – Monitoring of polystyrene production

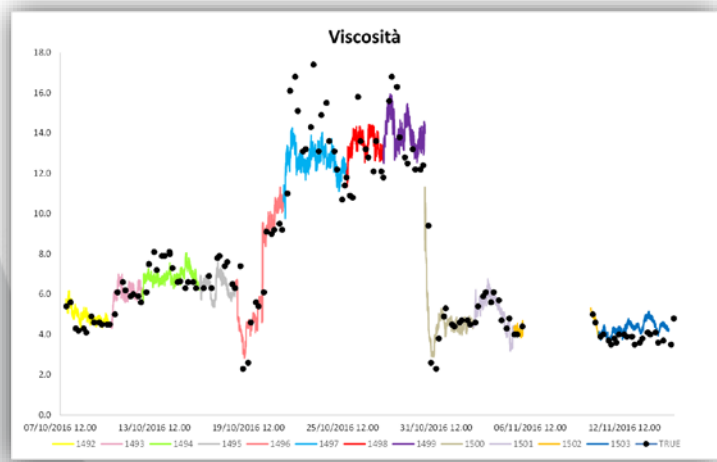
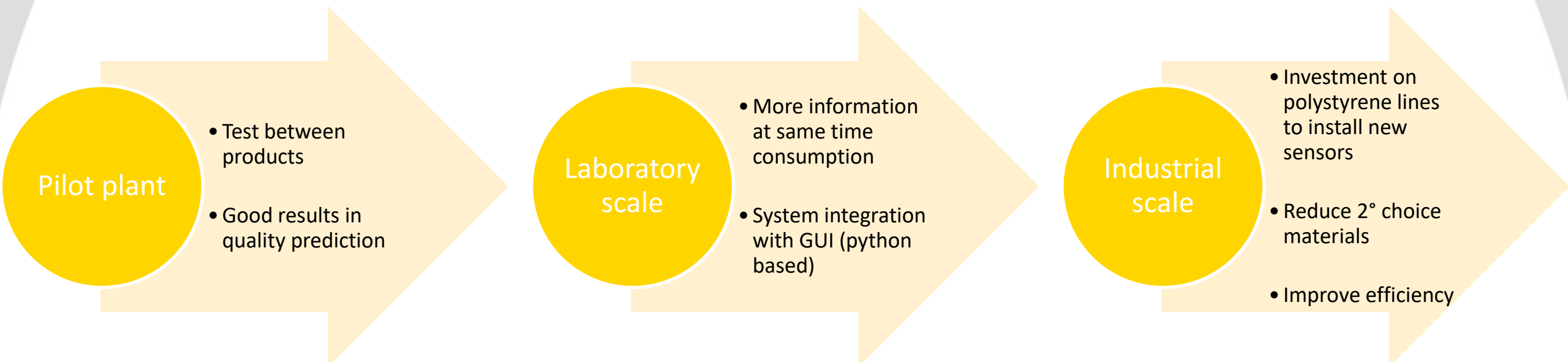

Peso della bandella prodotta durante analisi geli
 Pressione media durante analisi geli

The screenshot shows a software interface with various control panels:

- Top Panel:** Includes dropdown menus for 'ST18', 'ABS', and 'BS32E', along with 'Partita' and 'Tipo' fields.
- Acquisizione spettro:** A section with a 'Tempo di misura: 500 sec' field.
- Parameters:** Fields for 'Peso (g)', 'Pressione', and 'Giri (RMP)' (set to 60).
- Temperature Profile:** A section titled 'Profilo temperatura --> Testa' with buttons for '200', '210', '210', and '220'.
- Calendar:** A calendar for June 2018, with the date '26/06/2018' highlighted.
- Buttons:** 'Calcolo parametri' and 'Rilascio e LPG' buttons are visible.





Lack of quality in polymers production: Troubleshooting analysis

Task – Lack of quality in production



Polymer pellets

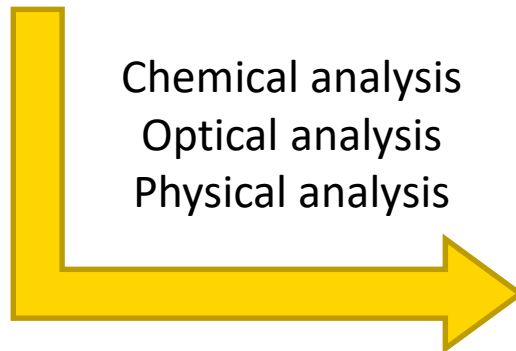

Item performances

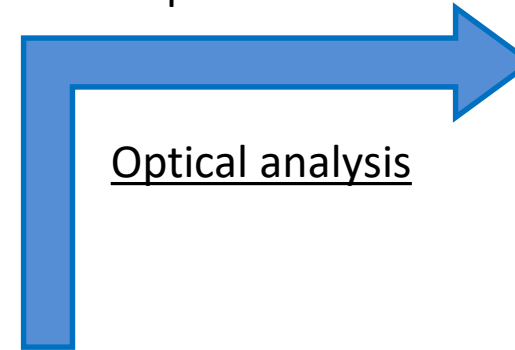

Optical analysis

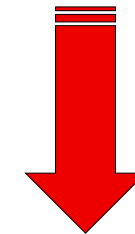

- Minor market share
- Lower profit
- Poor efficiency

Database – Lack of quality in production

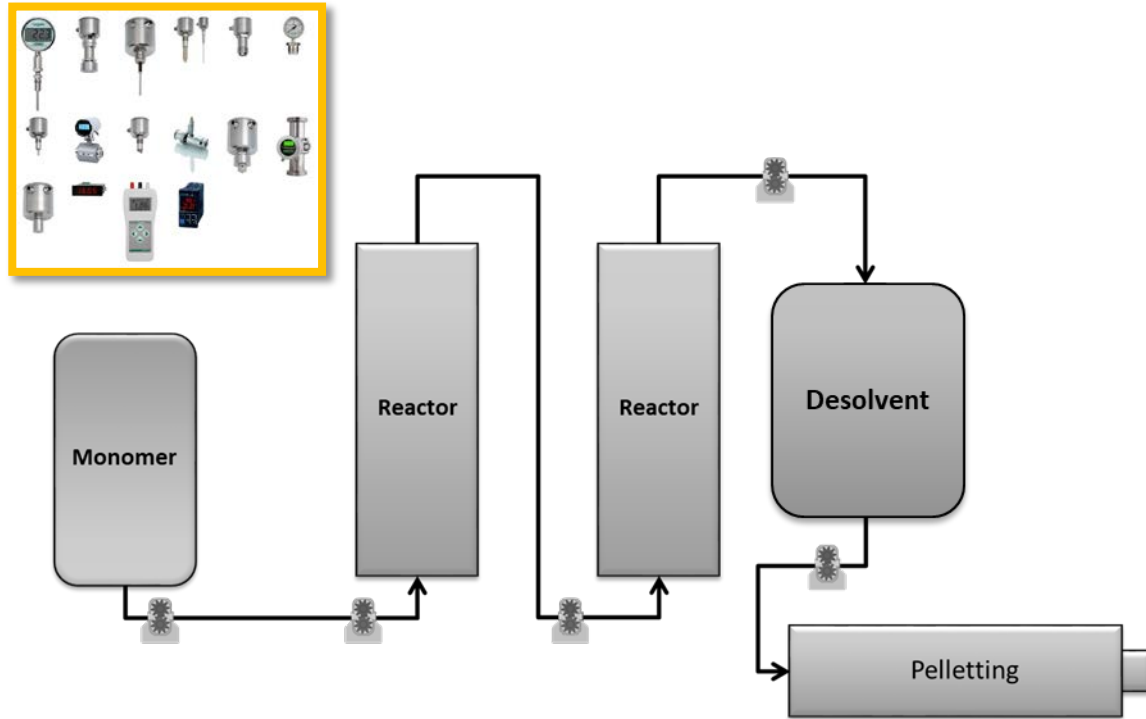

Data analysis

- Pre-treatment
- Decomposition
- Supervised classifications



5000 Observations
X
127 Variables

Customer
feedback

- *Production sensors*
(Thermocouples, flowmeters, level gauges, etc.)
- *Daily data sampling*
(Average of available measurements)
- *Historical dataset from 2010 to 2018*

Analysis – Lack of quality in production

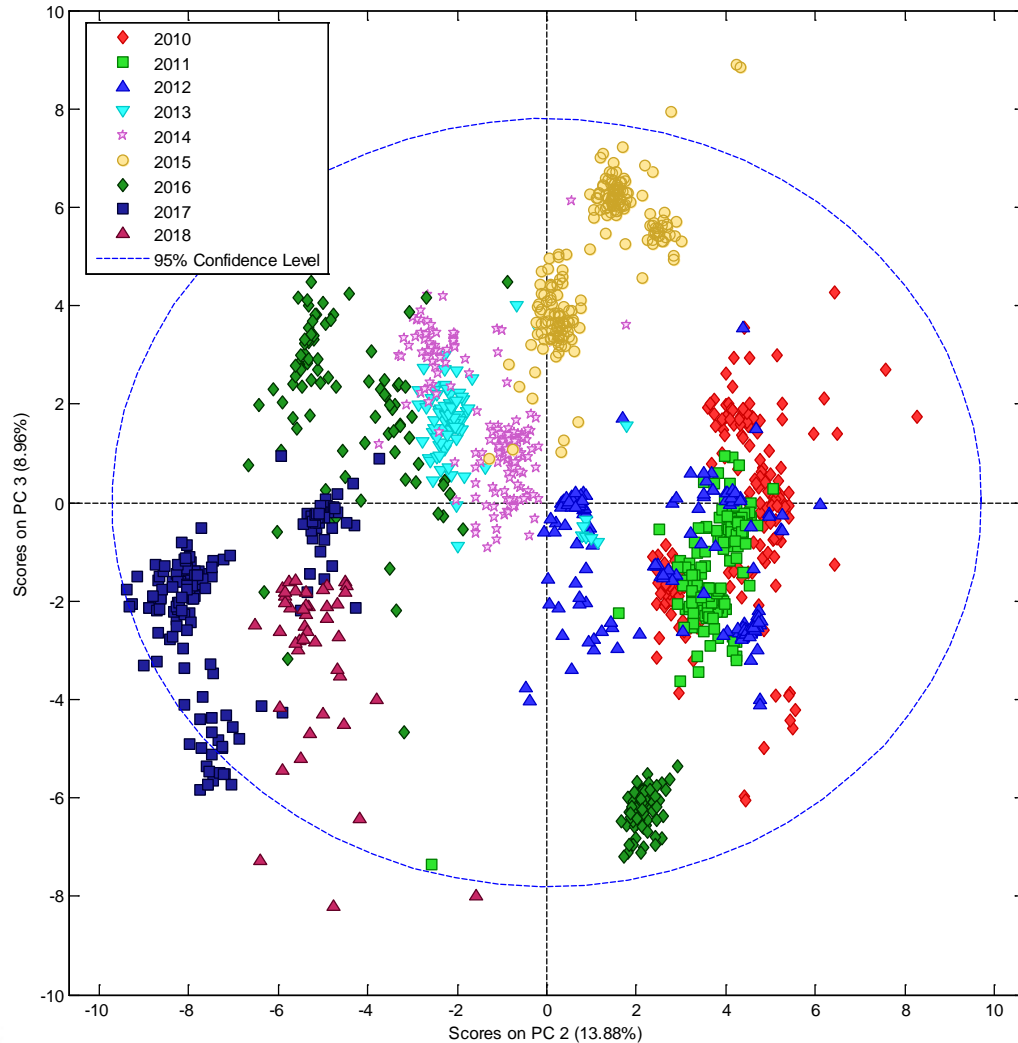

Data analysis

- Pre-treatment
- Decomposition
- Supervised classifications

PCA

5000 Observations
X
127 Variables

Customer
feedback

Analysis – Lack of quality in production

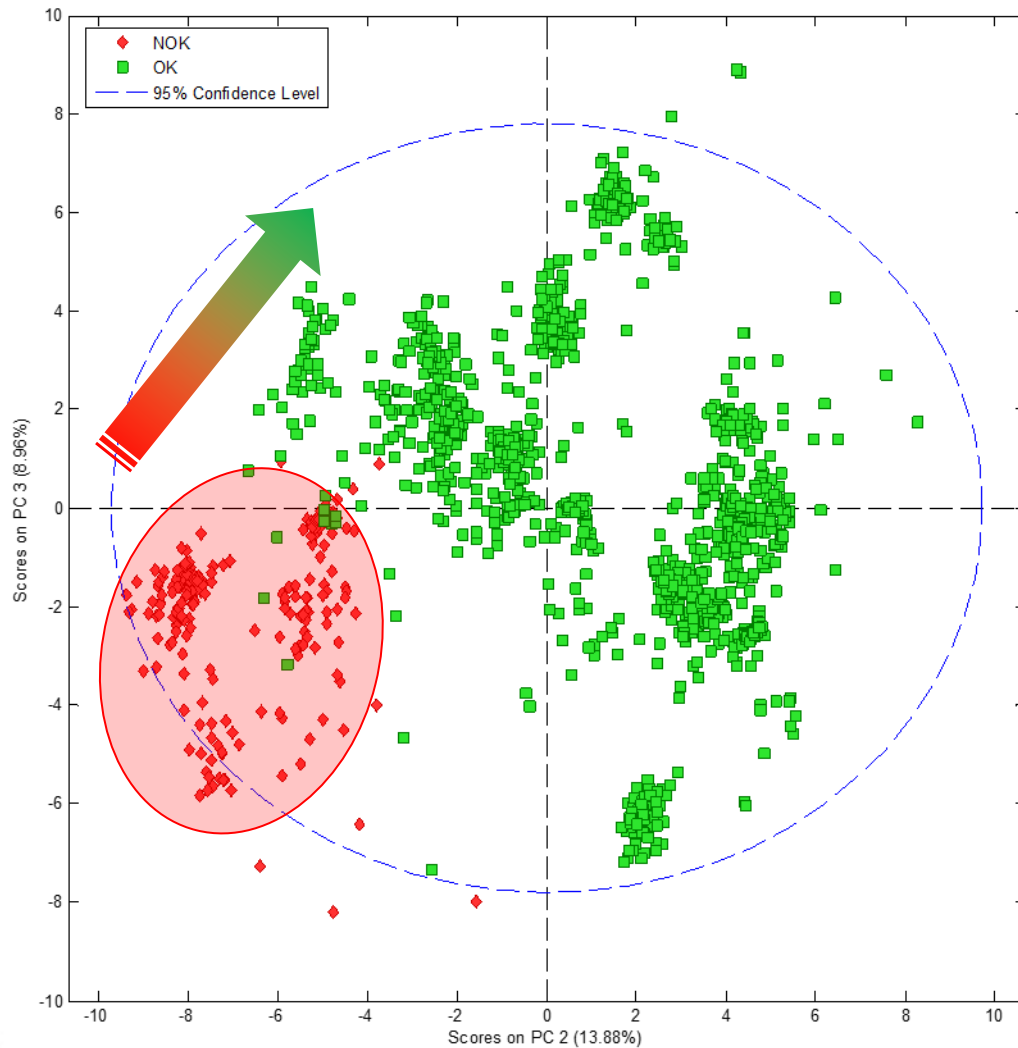

Data analysis

- Pre-treatment
- Decomposition
- Supervised classifications

PCA

5000 Observations
X
127 Variables

Customer
feedback

Analysis – Lack of quality in production

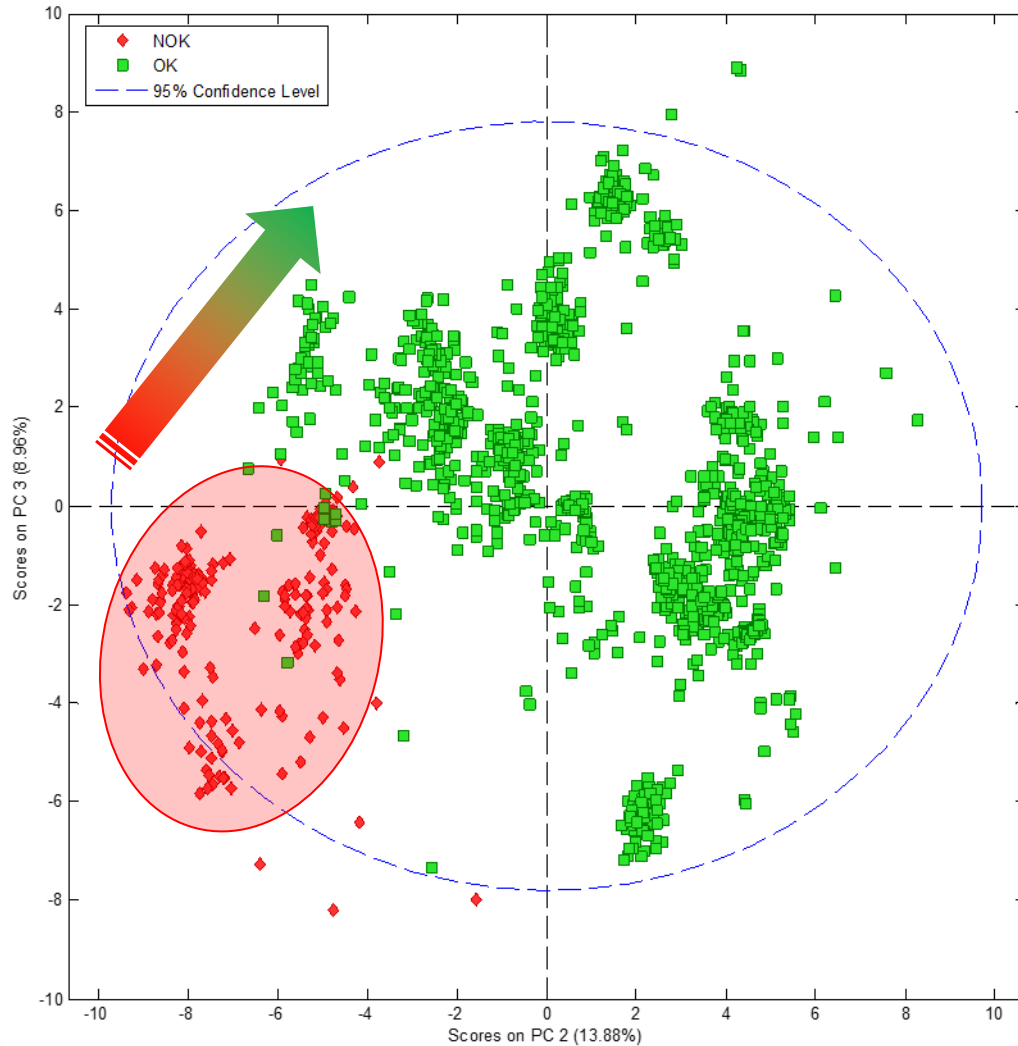

Data analysis

- Pre-treatment
- Decomposition
- Supervised classifications

PCA

PC2 vs. PC3 clearly separate plant conditions between In/Out of quality production.

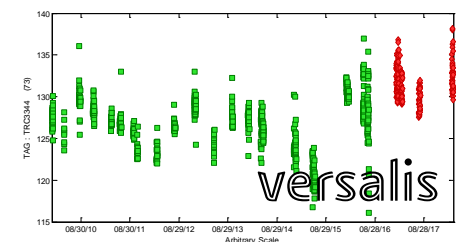
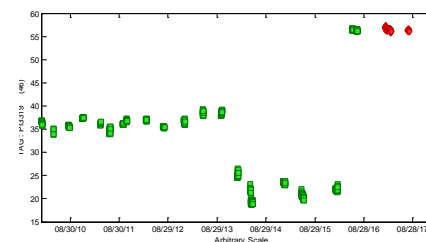
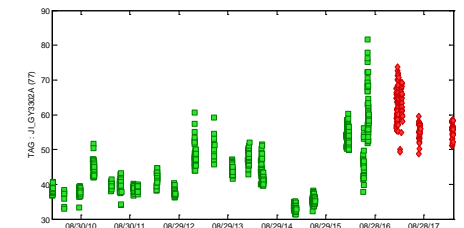
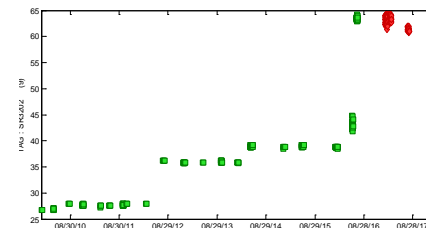

Information – Lack of quality in production

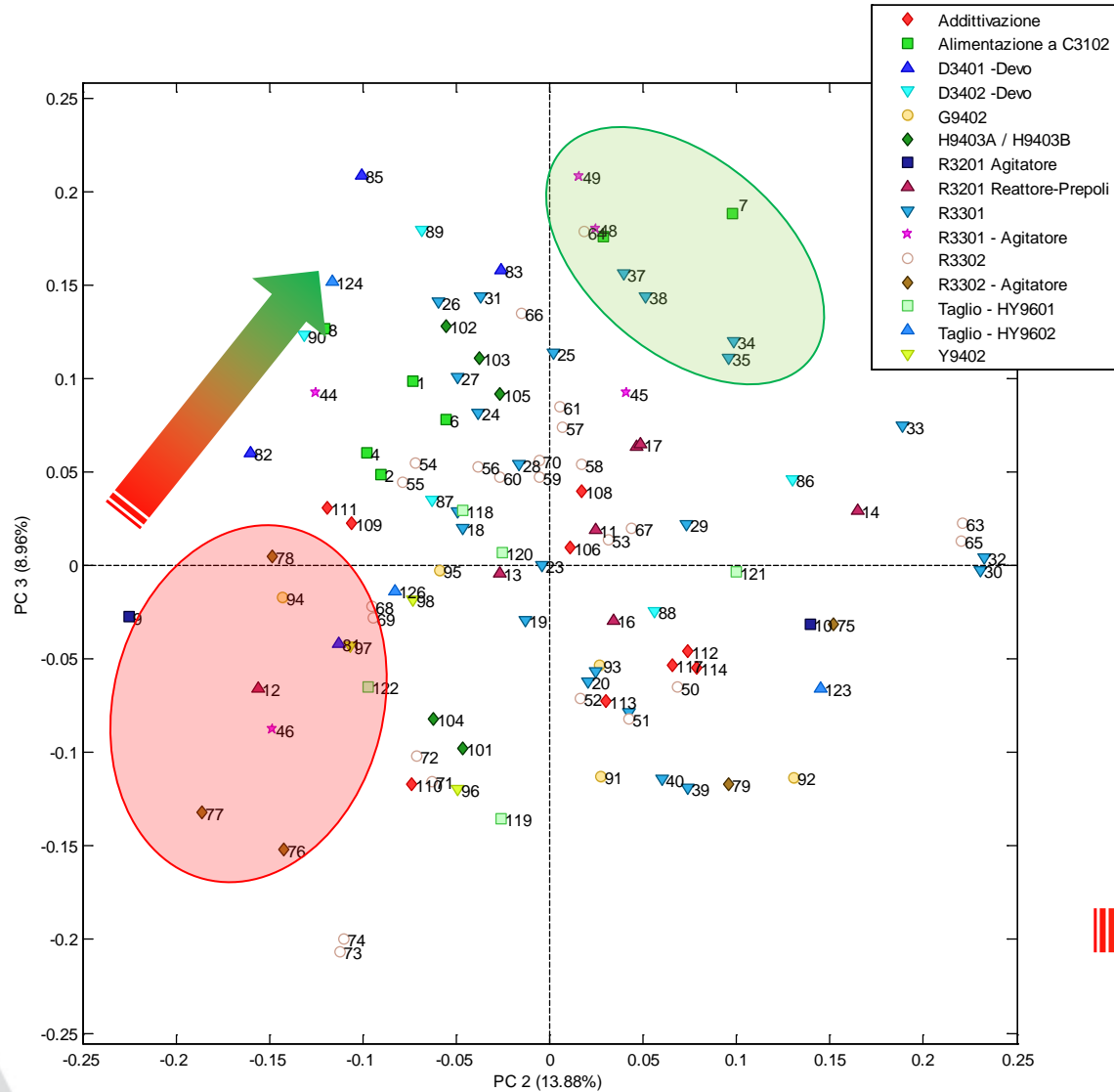

PCA

Data analysis

- Pre-treatment
- Decomposition
- Supervised classifications

PC2 vs. PC3 clearly separate plant conditions between In/Out of quality production.

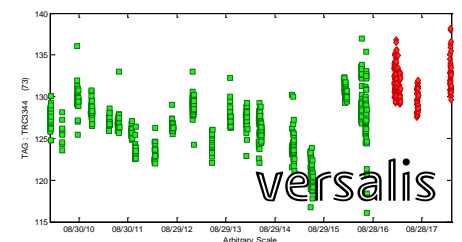
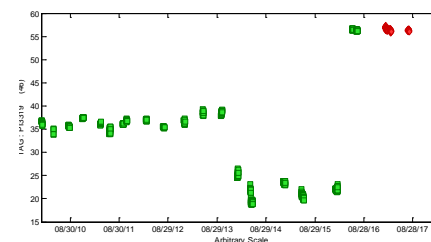
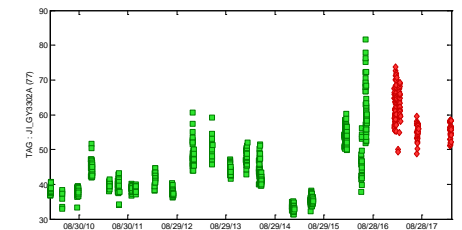
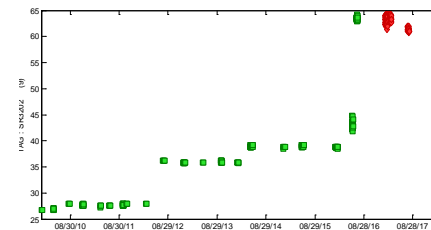

versalis

Action – Lack of quality in production

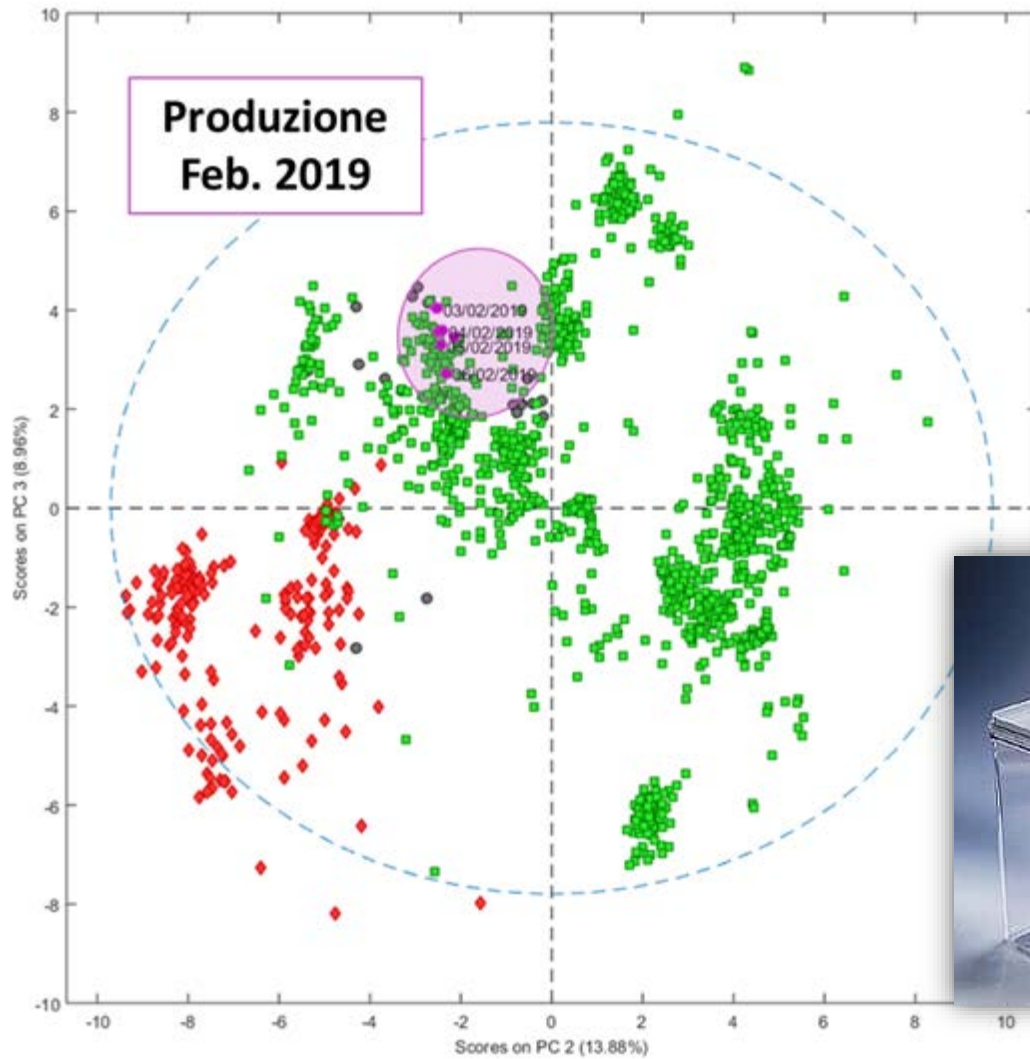

Item performances

Optical analysis



- Gain market share
- Back to previous profit
- Efficiency still under investigation



Final remarks – Versalis and Digital Transformation



- *Investment throughout different departments and technologies*

Industria 4.0

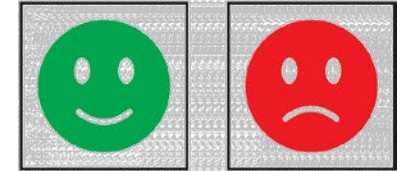

Costs

- *New approach to manage everyday challenges*

New results

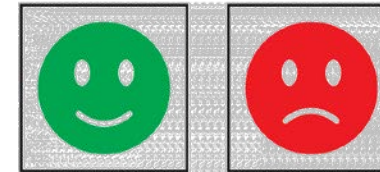

Misunderstanding

- *Employees training*

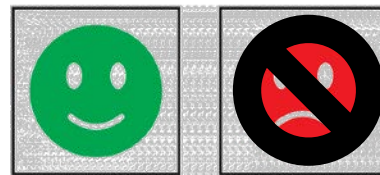

Integration a new correlation

- *Connection between production lines – research – safety*

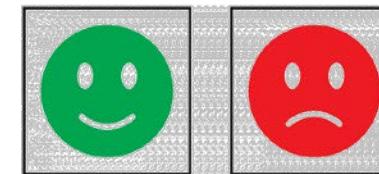

Manage communication